

Panel Applications

ASCO relay control panels were originally designed to New York City Board of Education specifications to operate ASCO DC solenoid valves controlling gas flow to school kitchens, domestic cooking classes, ceramic and metal shops. Because of its many features and silent operation, the ASCO relay panel has also been used in many other similar institutions and schools outside New York City. Vandalism and malicious mischief have caused some city governments to make it mandatory that the gas supply be locked off during closed hours. Other governmental bodies and consulting engineers have recognized the need and specifying the ASCO relay panel although not mandated by code.

ASCO relay panels are also used in industrial and commercial installations to control various gases and fluids.

Operations

Operating the key switch on the control station energizes the relay to open a normally closed ASCO DC solenoid valve which turns on the gas flow.

Panel Features

- ASCO's reputation and long experience in control are assurances of highly dependable systems with complete ASCO coordination.
- If the control voltage is lost completely, or reduces to approximately 50% of normal value, the relay de-energizes the normally closed valve to shut off gas flow.
- The valve will not open at restoration of voltage until an authorized person operates the key switch on the control station. This eliminates the danger of gas unknowingly escaping. The gas may also be shut off by depressing the normally closed pushbutton switch located on the control station.
- For convenience, auxiliary push-buttons, such as the ASCO Catalog numbers 173A19 and 173A20 may be located at various accessible points throughout the building.
- Utilization of DC control provided by the relay panel eliminates annoying AC hum.
- Shallow-depth NEMA Type 1 flush-mounted enclosure permits installation directly into the wall for convenience and elimination of obstructions in corridors or high traffic areas.
- ASCO dust-tight industrial relay and solid-state rectifier are designed to provide long life.
- Clearly marked terminals and installation drawings are located on inside of door.
- Approved by New York City Board of Education for use in public schools.

Control System Schematic

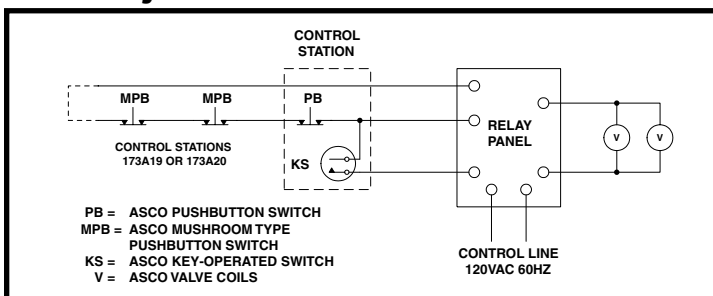

108D10C



108D90C

ASCO Relay Panel

Catalog Number: 108D10C

Input Voltage: 120 volts, 60 Hz

Output Voltage: 80 volts DC

Output Current: 0.8 amp maximum

Note: No buttons on cover

AC Relay Control Panel

Catalog No. 108D90C (replaces AEP 7200) provides similar features as the DC panels described above except for its 120/60 AC voltage output, and a key-operated switch with manual "on" and "off" buttons on the cover.

(Has not been submitted for N.Y.C. Board of Education approvals.)

Panel 108D10C Dimensions

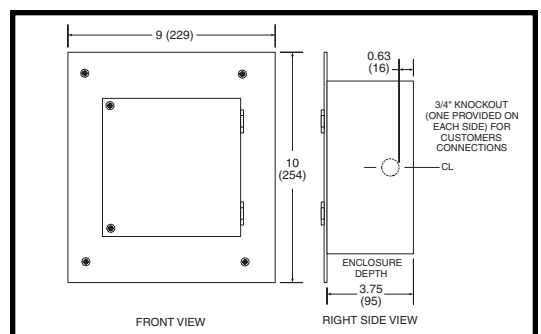

MASTER CONTROL STATION

(For use with Panel 108D10C)

Catalog No. 216C89 consists of a key-operated, normally open switch and a normally closed pushbutton mounted in a stainless steel faceplate for flush installation. "Gas Valve Control" is inscribed on the faceplate, and the switches are labeled "Open" over the key switch and "Shut" over the pushbutton. Four inch square wall box is not included.

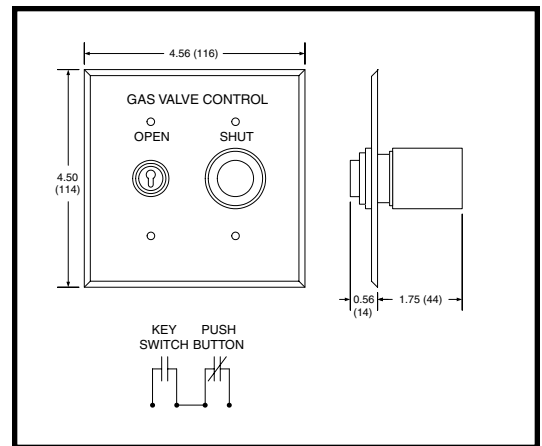

CONTROL STATIONS

Catalog No. 173A19 (flush mounted) and Catalog No. 173A20 (surface mounted) consist of a momentary mushroom pushbutton labeled "Emergency Stop." When button is hit, power to valves is shut off and they close in 0.1 second.

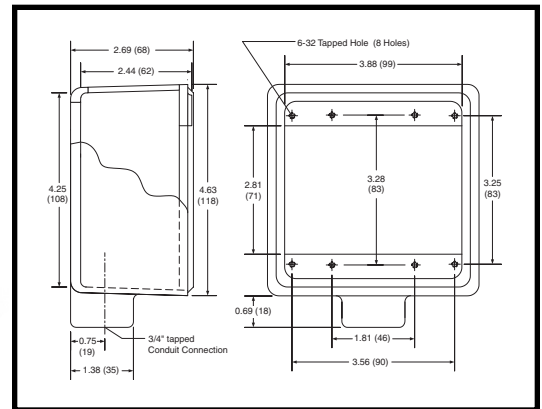

SOLENOID VALVES

Series 8215 Solenoid Valves feature 2-way normally closed operation for gas service. They are explosionproof and designed to handle low pressure city gas. Control voltage is 80 to 90 volts DC or 120/60 volts AC.



DC Valves for use with Panel 108D10C

Pipe Size (ins.)	Catalog Number	Max. Pressure psi (bar)	Cv (Kv) Flow Factor	Holding Watts
1/2	EF8215G020	25 (1.7)	4.4 (3.8)	11.6
3/4	EF8215G030	25 (1.7)	5.1 (4.4)	11.6
1	EF8215B050	25 (1.7)	21 (18.2)	14.9
1 1/4	EF8215B060	25 (1.7)	32 (27.7)	14.9
1 1/2	EF8215B070	25 (1.7)	35 (30.3)	14.9
2	EF8215B080	15 (1)	60 (51.9)	14.9

AC Valves for use with Panel 108D90C (replaces AEP7200)

Pipe Size (ins.)	Catalog Number	Max. Pressure psi (bar)	Cv (Kv) Flow Factor	Holding Watts
1/2	EF8215G020	50 (3.4)	4.4 (3.8)	10.1
3/4	EF8215G030	50 (3.4)	5.1 (4.4)	10.1
1	EF8215B050	25 (1.7)	21 (18.2)	15.4
1 1/4	EF8215B060	25 (1.7)	32 (27.7)	15.4
1 1/2	EF8215B070	25 (1.7)	35 (30.3)	15.4
2	EF8215B080	25 (1.7)	60 (51.9)	15.4

Solenoid Valves

Order by Catalog Number and Voltage (Ex. EF8215G020 80-90VDC)

Contact ASCO Valve, Inc. at 800-972-2726
www.ascovalve.com

Gas Panels, Master Stations, and Control Stations

Order by Catalog Number (Ex. 108D10C)

Contact ASCO Power Technologies at 800-800-2726
www.ascopower.com